

Junttan PMX20 Information Sheet



Technical Data

Types of Piles	Steel, Concrete and Timber.
Length telescopic leader	Max 23.48m Min 19.48m
Base Machine	Junttan
Transport Weight	56.8 & 58 Te
Transport Height	3.7m
Transport Width	3.2m
Transport Length	20.5m
Hammer Type	SHK100-4/5
Stroke	Variable 0 – 1200mm
Nominal Bearing Pressure	Approx 200kN/m ²
Max Pile Length	15m
Maximum Leader Rake	Refer to Operators Manual

Working Conditions

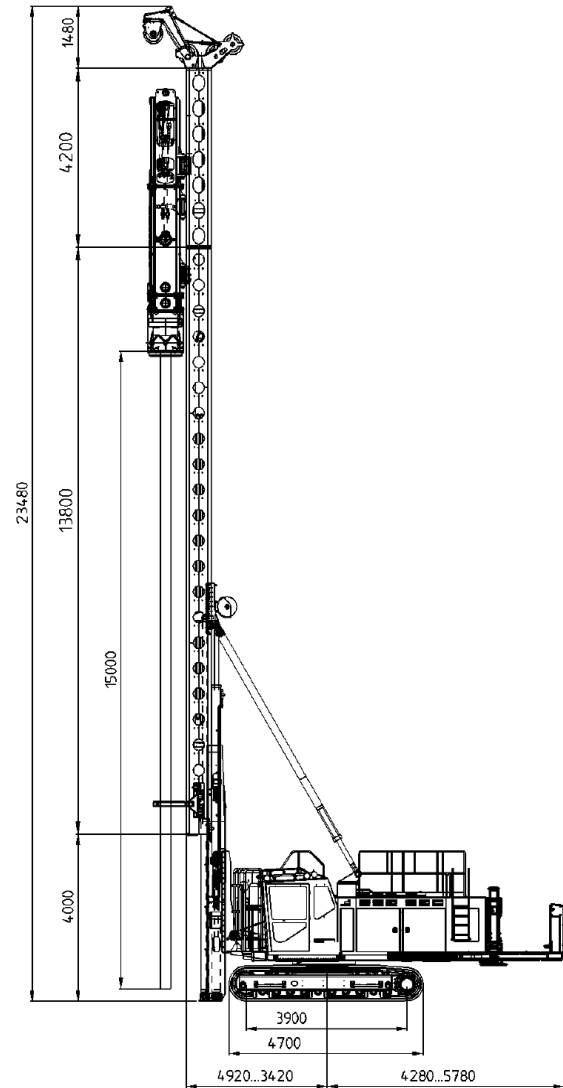

Transport Conditions

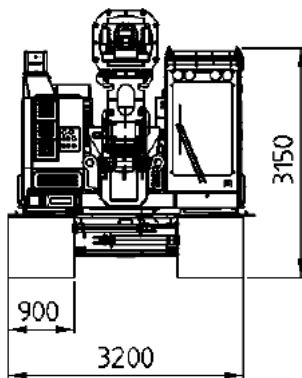

Transport Conditions

