

# Junttan PM20/L/LC Information Sheet

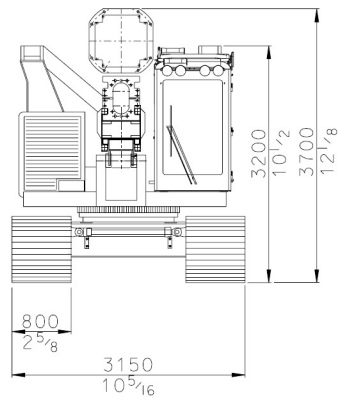

## Technical Data

<b>Maximum Leader Rake</b>	Backwards	45°	1:1
	Forwards	16°	1:3:5
	Sideways	7°	1:8
<b>Length telescopic leader</b>	Max	21.3m	
	Min	17.9m	
<b>Base machine</b>	Junttan		
<b>Transport weight</b>	48, 54 & 59 Te		
<b>Transport height</b>	3.7m		
<b>Transport width</b>	3.2m		
<b>Hammer type</b>	HHK 4a & 5a accelerated		
<b>Stroke</b>	Variable 0 – 1200mm		
<b>Nominal bearing pressure</b>	200 – kN/m <sup>2</sup>		



Minimum track width.

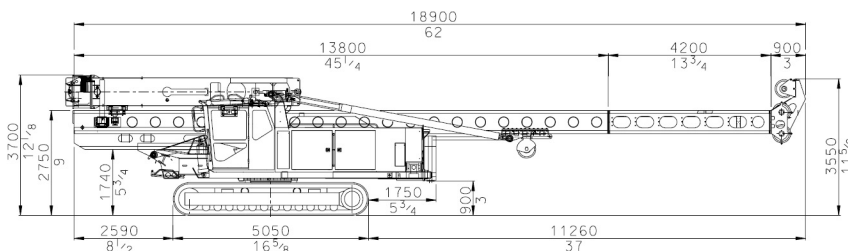

Standard PM 20LC transport dimensions with HHK 5A hammer.

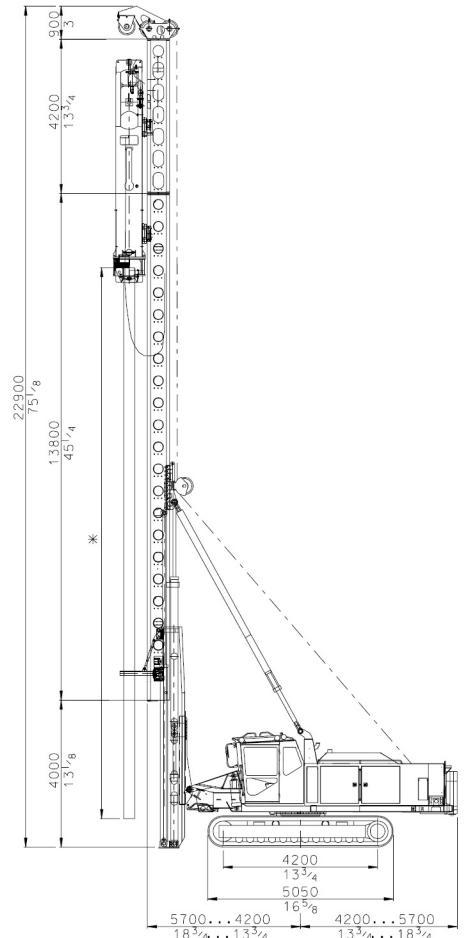

Standard PM 20LC with top cathead